

Gardner
Denver

POSITIVE DISPLACEMENT BLOWERS & VACUUM PUMPS

CycloBlower[®] H.E. Series



THE **Best**
Blower
WE HAVE
Ever MADE

It's all about the... **LEGACY**

The ORIGINAL Rotary Screw Blower

A Reputation Earned by a Proven History
of Quality, Reliability, and Performance





Experience Matters: Over 25,000
CycloBlower Installations World-Wide

It's all about the...

EVOLUTION

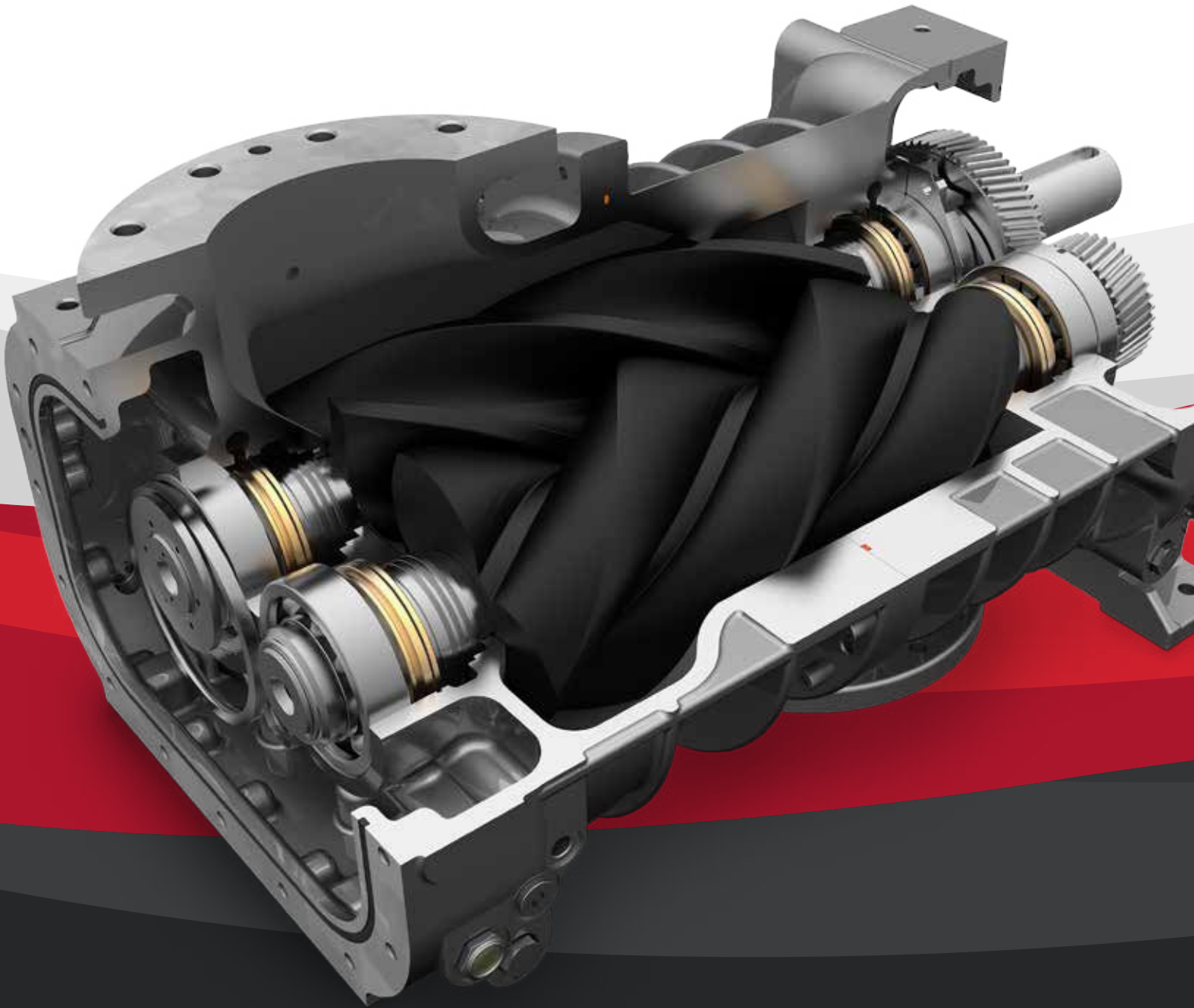

THOROUGHLY RESEARCHED | PRECISELY CALCULATED
CAREFULLY MODELED | METICULOUSLY TESTED | SUCCESSFULLY DEVELOPED

Introducing the CycloBlower H.E. Series

- Best-in-Class Energy Efficiency
- Game-Changing Patented Design
- New Level of Performance:
up to 36 psi, 22 inHg, 6,200 cfm
- Built with Best-of-the-Best Components
- Flexible Options & Installation

CycloBlower has been **reinvented**
as the **most efficient blower**
on the market today

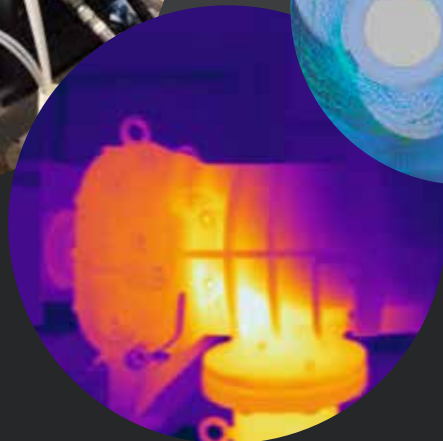
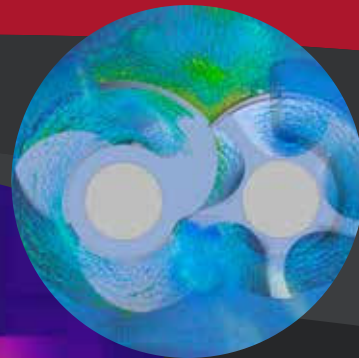

It's all about...

SAVING MONEY

TOTAL COST of Blower ownership



- Energy
- Maintenance
- Investment

- Energy consumption is typically the largest cost of ownership
- Save BIG with best-in-class energy efficiency
- Lower your bottom line, increase your profits

*Invest Wisely =
Reduce Energy =
Save Money*



Brake Horsepower
Requirement Comparison
at 2000 CFM

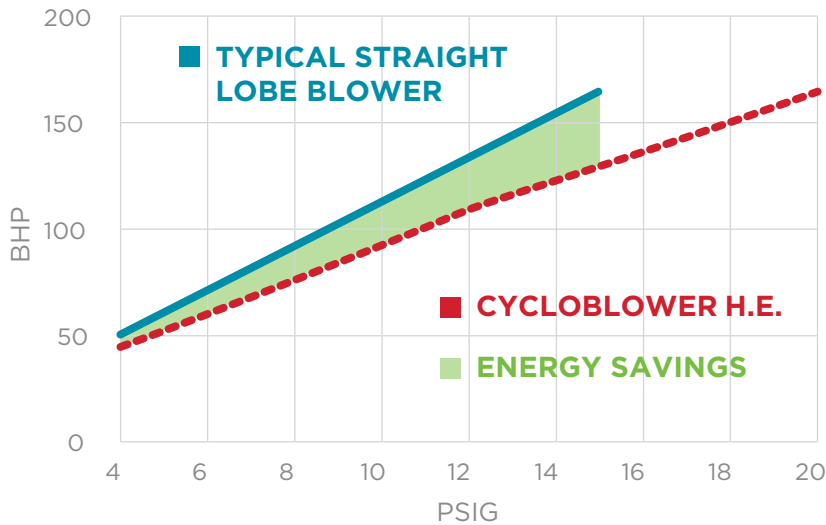

Innovation Working
for You!

In many comparable applications, the CycloBlower operates more efficiently than other straight-lobe blowers. By requiring less brake horsepower (BHP) energy operating cost can be realized and greatly reduced.

CYCLOBLOWER H.E. VS. STRAIGHT LOBE

BLOWER TECHNOLOGY	BHP USED @ 15 PSI	ENERGY COST PER YEAR
Standard Straight Lobe	163	\$106,695
CycloBlower H.E.	129	\$84,604

\$22,090
ANNUAL SAVINGS

*Calculations based on the cost of providing 2,000 cfm of air for 8760 hours (1 year of 24/7 operation) assuming motor drive efficiency of 90% and electricity cost of \$0.09/kWh.



It's all about the...

PATENTED DESIGN

Market-Leading Performance

- Patented, highly-efficient 3×5 helical screw rotor profile provides a competitive advantage for you
- Food-grade PTFE (Polytetrafluoroethylene) coated rotors minimize air loss while maximizing efficiency

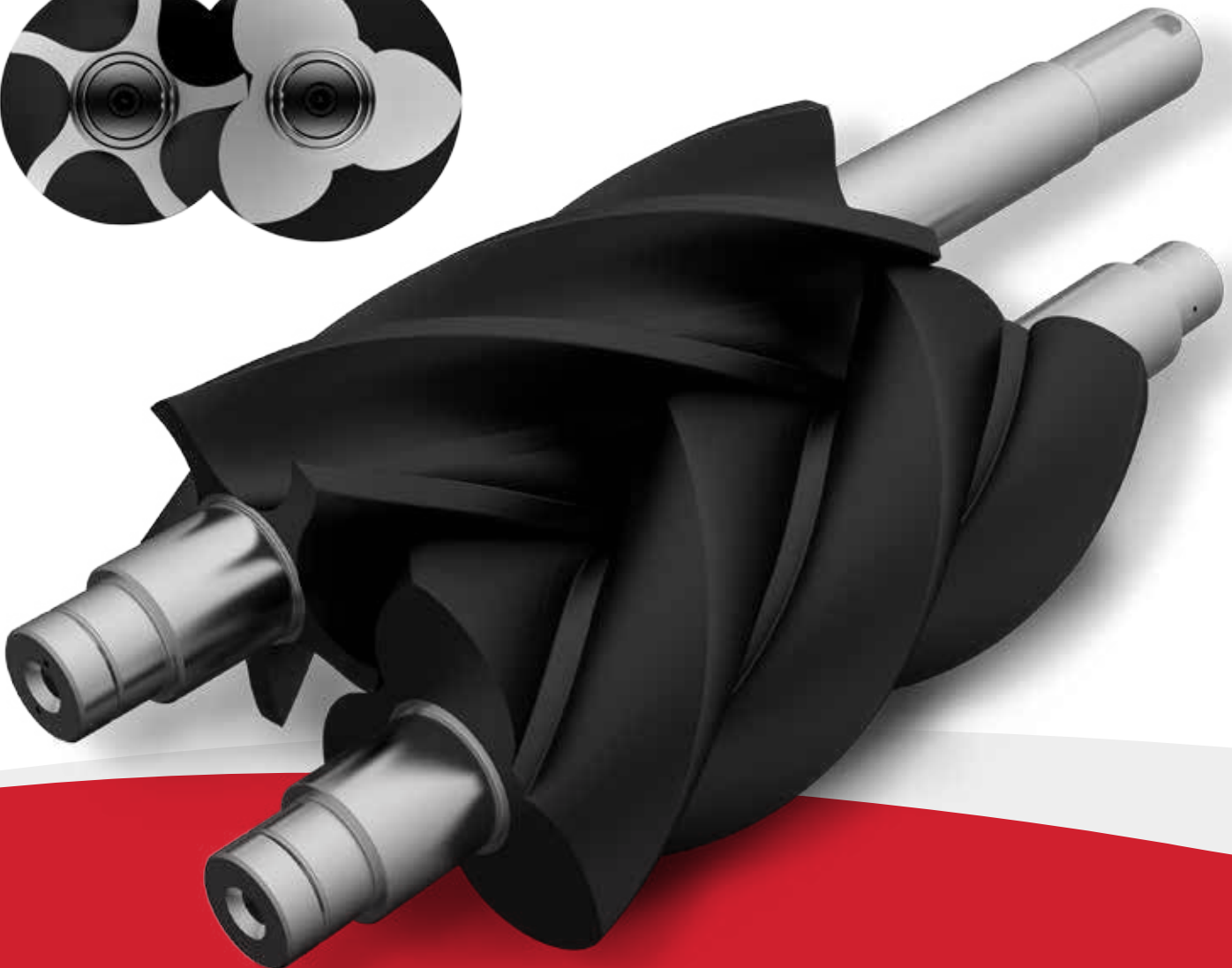
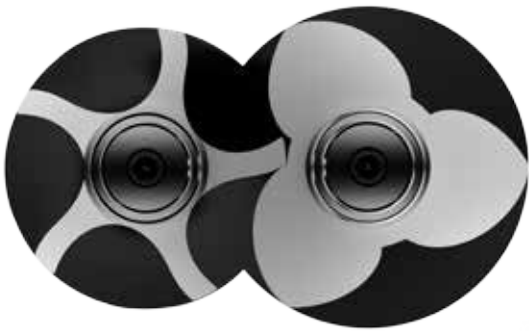

Enhancing Performance Through Innovative Design

- Exclusive split-cylinder design matches performance to your application requirements
- Three discharge port options optimize efficiencies based on your specific performance needs



Optimized Efficiency
Modified Cylinder for Maximized Savings

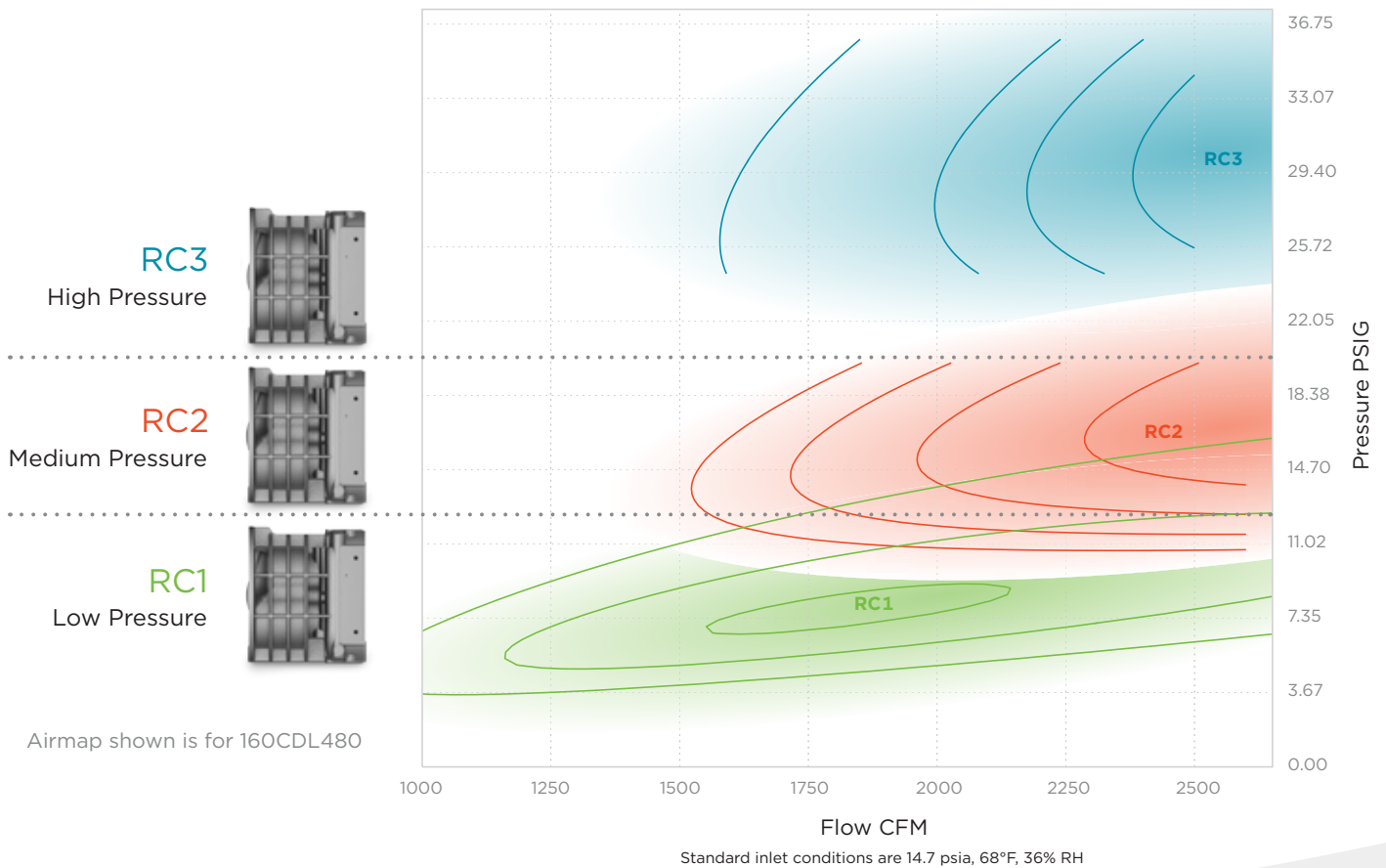

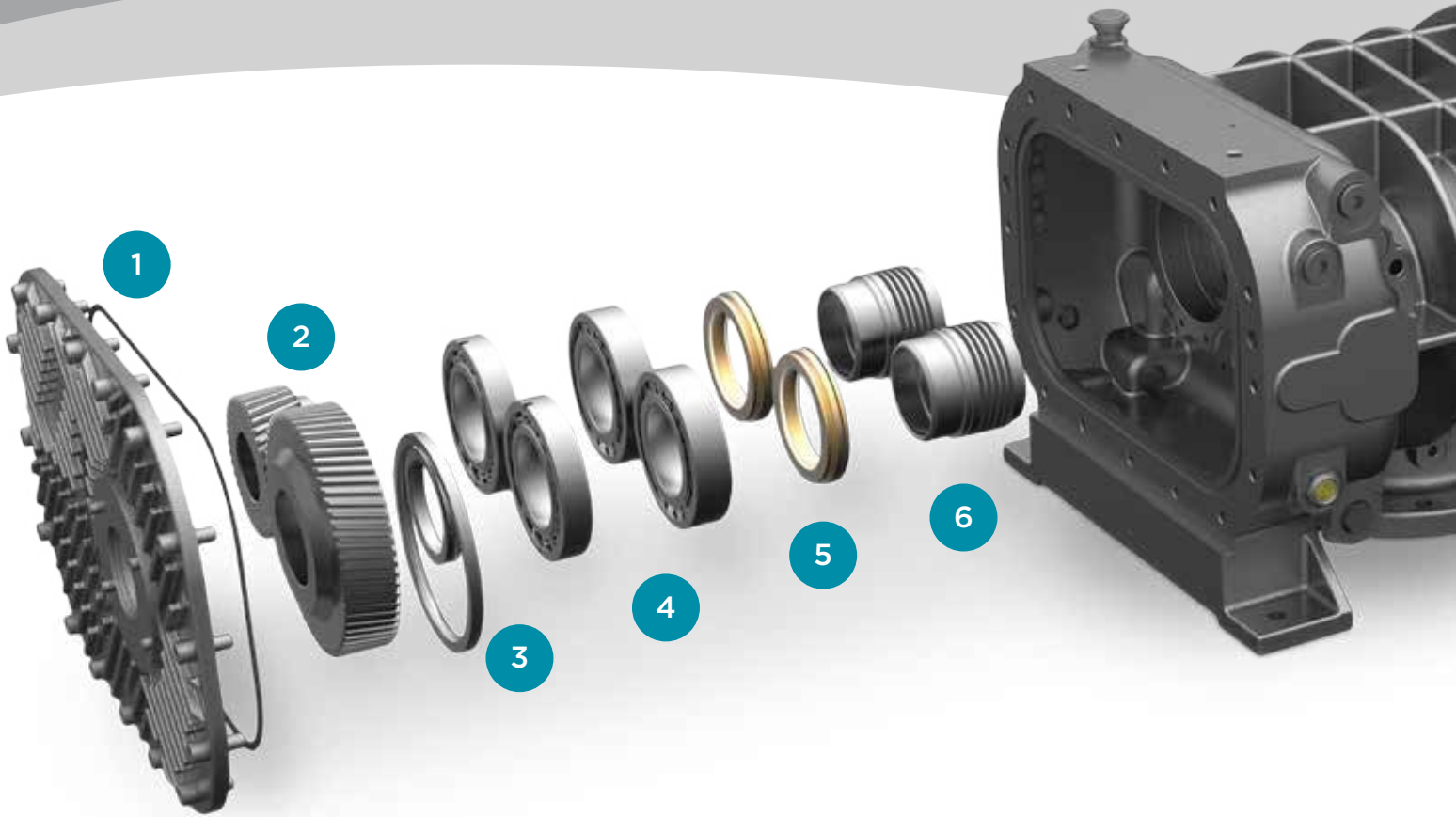

It's all about...

the COMPONENTS

BEST OF THE BEST

No Corners Cut | No Compromise | Premium Parts
Quality Confidence | Beyond Expectations

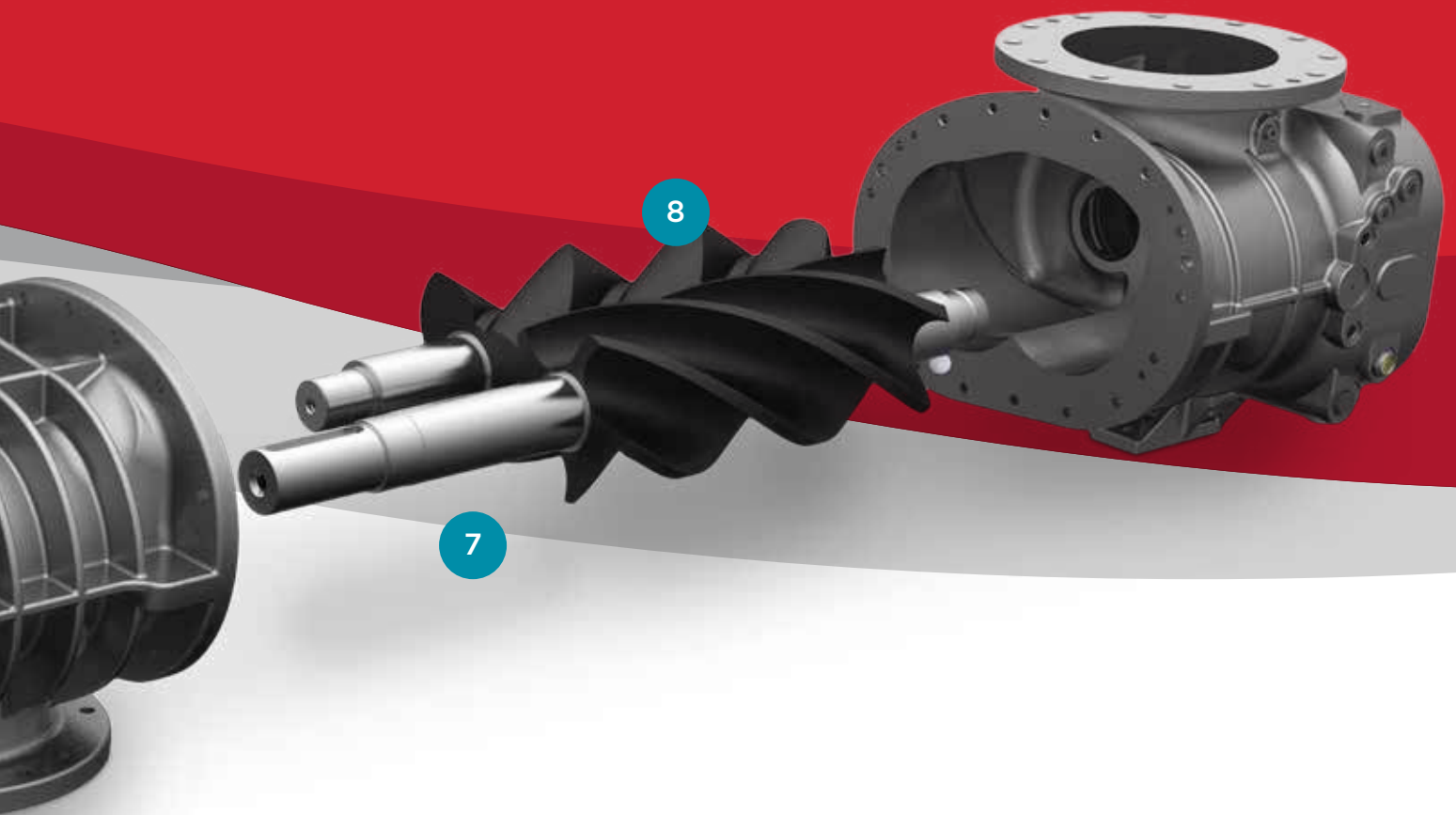

To learn more about Inpro/Seal
visit www.inpro-seal.com or
scan the QR code to the right



1 O-Rings

- O-Ring Seals
- Durable Protection
- No Gaskets

2 Helical Timing Gears

- Smooth, Quiet Operation at All Speeds
- Assures Non-Slip Rotor Timing

3 Dual-Splash Lubrication with Eccentric Slinger Ring

- Unique Design
- Maximizes Efficiency by Reducing Power Consumption
- Optimizes Oil Distribution

4 Discharge Bearings

- Axial: 4 Point Angular Contact Bearings
- Radial: Cylindrical Roller
- Provides Absolute Strength and Stability on Multiple Planes to Handle Extreme Applications
- Extended Bearing Life

5 Inpro/Seal® Premium Oil Seal*

- Contactless Dual-Ring Design
- Non-Wearing
- Extends Longevity Reducing Maintenance Costs
- Market-Leading Protection Against Leaks

6 Piston Ring Air Seals

- Delivers Leak-Free Operation
- Provides Maximized Seal Life
- Graphite air seals for high pressure applications over 20 PSI

7 Robust Ductile Iron Shaft

- Designed & Tested for Strength
- High Shaft Load Capacity
- Direct & V-Belt Drive Capable

8 PTFE (Polytetrafluoroethylene) Coated Rotors

- Food Grade
- Minimizes Air Loss
- Maximizes Efficiency

*Inpro/Seal is a registered trademark of Waukesha Bearings Corporation

It's all about...

OPTIONS

Force Feed Lubrication

- Ensures Cool Oil Temperature and Distribution
- Optional for Applications up to 20 psi
- Required for Applications Greater than 20 psi

working for your

APPLICATION

Sustainable Performance for a Wide Range of Applications



Cement



Wastewater Treatment



Pneumatic Conveying



Power G

Mechanical Seals

- For Gas Applications
- Interchangeable with Inpro/Seal

PTFE (Polytetrafluoroethylene) Coated Cylinder

- Minimizes Air Loss
- Maximizes Efficiency

Graphite Air Seals

- Required for High Pressure Applications Over 20 psi

Low, Medium & High Pressure Discharge Cylinder

- Optimizes Efficiencies
- Unique Technology

Installation Flexibility

- Top and Bottom Discharge Orientations
- 3 and 4 Mounting Foot Configurations Available
- ANSI or Metric Flanges

RTD Ports & Probes

- Designed to Ensure Precise and Accurate Bearing Temperature Measurements



Generation



Plastics



Chemical Processing



Food & Beverage

It's all about...

HIGH PRESSURE CAPABILITY

- Force Feed Lubrication required for:
 - Pressures above 20 PSI
 - Vacuum above 18"Hg
- Maintains optimum oil temperatures
- Filters the oil
- Monitors oil temperature and pressure
- Maintains vacuum on the oil sump
- Injects oil at critical locations
 - Injects oil into bearings at optimal point
 - Injects oil onto gears in the ideal location
- System utilizes 220V/240V, 50Hz/60Hz single-phase electric supply
- JIC Hose Connections

Protected System with Smart Controls:

- The Force Feed Lubrication Pallet monitors the system within specified fault limits.
- If any sensors detect operation outside limits, contacts in the control box go into fault condition.
- Fault Contacts -Two fault contacts (one normally open, one normally closed) are provided to indicate a lubrication system fault.
 - At least one fault contact must be used to disable the main blower motor.
- Remote Control Contact -A remote RUN/RESET contact is also available. With the manual system control switch in the ON position, a closure between the remote run contact energizes the fan and activates the time delay relay.



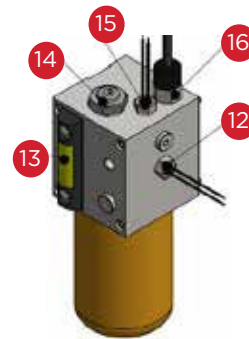
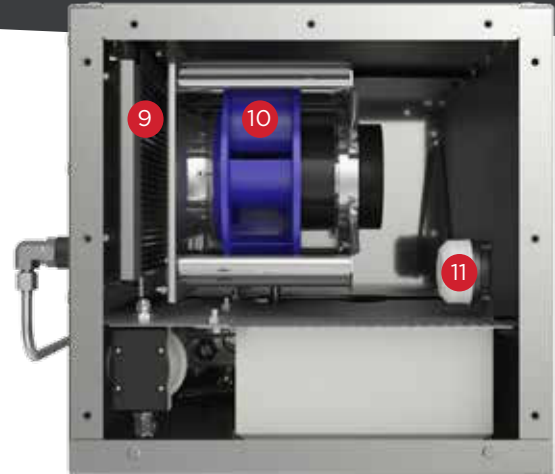
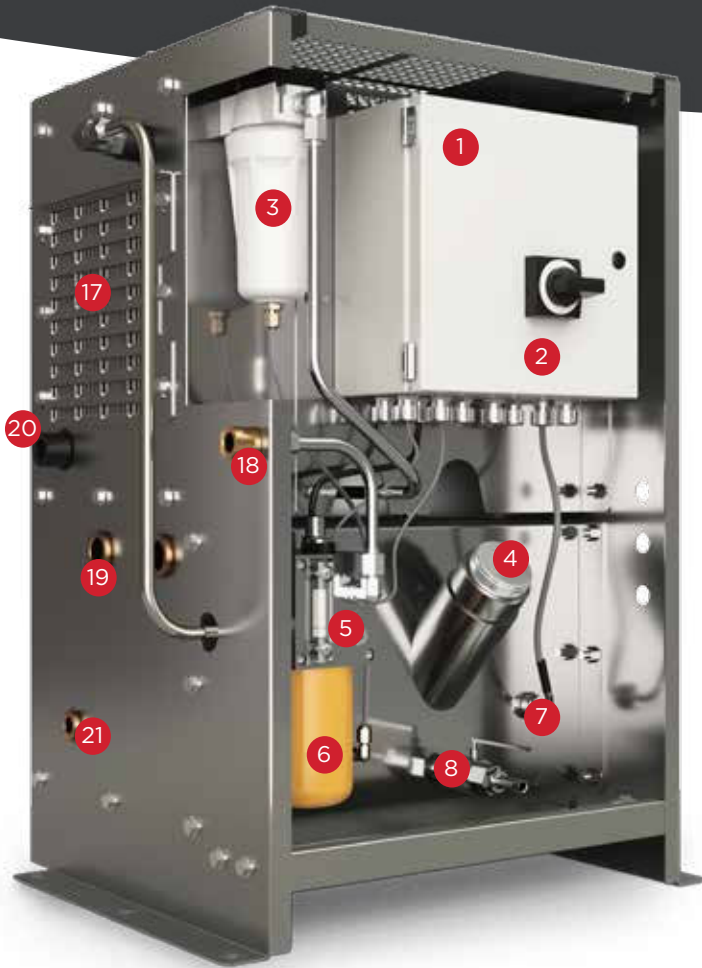

- | | | |
|---|--|---|
| 1 Control Box | 9 Heat Exchanger w/ Internal Thermal Bypass | 16 Low Oil Pressure Fault Switch |
| 2 Manual System Control Switch | 10 Backwards Curved Centrifugal Fan | 17 Adjustable Louver for Air Pressure Regulation |
| 3 Coalescing Filter for Oil Mist Removal | 11 Low Reservoir Vacuum Switch | 18 Blower Oil Injection Connection (1/2" JIC) |
| 4 Oil Fill Cap | 12 Low Oil Temperature Fault Switch | 19 Blower Drain Line Connections (1" JIC) |
| 5 Oil Control Block Assembly | 13 Oil Level Sight Glass | 20 Oil Pump Outlet Connection (1/2" JIC) |
| 6 Oil Filter | 14 Oil Pressure Regulation Valve | 21 Oil Pump Inlet Connection (1/2" JIC) |
| 7 Oil Heater with Internal Thermostat | 15 High Oil Temperature Fault Switch | |
| 8 Oil Drain Valve | | |

It's all about...

the INSTALLATION

As the **only rotary screw bare** blower on the market, the CycloBlower allows the flexibility to:

- Retrofit your existing package
- Package the way you want it packaged
- Upgrade your current package
- Maximize performance without maxing out your budget
- Compact footprint saves floor space

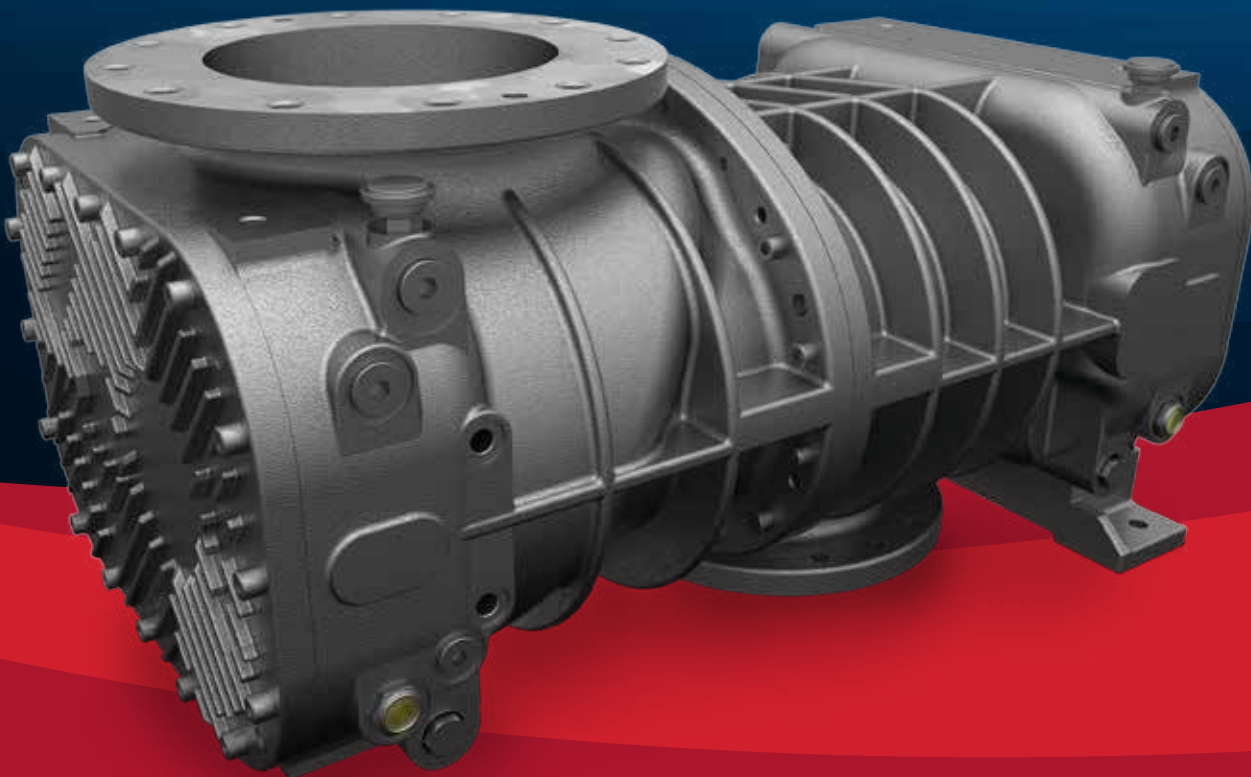

WE THOUGHT
OUTSIDE
OF THE BOX
TO SAVE MONEY
FOR YOU

DON'T WASTE MONEY ON CAPITAL EXPENSES
BY BUYING THE OVERPRICED, PREPACKAGED, INFLEXIBLE
UNITS. **CUSTOMIZE YOUR OWN PACKAGE** OR
RETROFIT YOUR EXISTING PACKAGE.

CycloBlower H.E. Performance Data

LOW PRESSURE - PERFORMANCE DATA

MODEL	SPEED RPM	5 PSIG		9 PSIG		12 PSIG		15 PSIG		18 PSIG		20 PSIG	
		CFM	BHP	CFM	BHP	CFM	BHP	CFM	BHP	CFM	BHP	CFM	BHP
160CDL480 RC1	1000	542.8	15.9	463.5	27.3	407.2	36.0	353.7	44.8	-	-	-	-
	1500	940.0	24.4	863.9	40.7	810.1	53.0	759.0	65.6	-	-	-	-
	2000	1340.2	34.0	1267.4	55.2	1216.0	71.2	1167.3	87.4	-	-	-	-
	2500	1743.5	44.8	1673.9	70.9	1624.9	90.6	1578.6	110.4	-	-	-	-
	3000	2149.7	56.8	2083.3	87.7	2036.7	111.1	1992.9	134.5	-	-	-	-
	3600	2641.1	72.6	2578.6	109.4	2535.0	137.1	2494.0	165.0	-	-	-	-
160CDL480 RC2	1000	509.0	18.2	471.8	26.2	443.0	32.9	413.3	40.0	382.8	47.8	-	-
	1500	893.2	29.4	856.4	41.3	827.9	50.9	798.5	61.0	768.3	71.6	747.8	78.9
	2000	1284.3	41.7	1247.9	57.4	1219.7	69.9	1190.6	82.9	1160.8	96.4	1140.4	105.7
	2500	1682.4	54.9	1646.4	74.6	1618.4	89.9	1589.7	105.8	1560.1	122.2	1540.0	133.5
	3000	2087.3	69.2	2051.7	92.7	2024.1	111.0	1995.6	129.8	1966.4	149.1	1946.4	162.3
	3600	2582.4	87.7	2547.3	115.9	2520.0	137.6	2491.9	159.9	2463.0	182.7	2443.3	198.2
160CDL480 RC3	1000	-	-	-	-	395.1	41.9	388.0	46.1	-	-	-	-
	1500	-	-	-	-	770.1	63.9	763.4	70.1	754.3	76.8	747.0	81.6
	2000	-	-	-	-	1156.6	87.4	1150.2	95.6	1141.6	104.3	1134.5	110.4
	2500	-	-	-	-	1554.6	112.5	1548.6	122.6	1540.2	133.3	1533.4	140.8
	3000	-	-	-	-	1964.0	139.2	1958.3	151.3	1950.3	164.0	1943.8	172.7
	3600	-	-	-	-	2470.3	173.3	2465.1	187.8	2457.6	202.8	2451.3	213.2

LOW VACUUM - PERFORMANCE DATA

MODEL	SPEED RPM	5 IN HG		8 IN HG		11 IN HG		14 IN HG		17 IN HG	
		CFM	BHP	CFM	BHP	CFM	BHP	CFM	BHP	CFM	BHP
160CDL480 RC1	1000	570.1	7.0	526.3	11.8	470.9	17.0	398.7	22.0	-	-
	1500	957.3	13.1	916.1	18.7	864.0	24.9	796.5	31.4	-	-
	2000	1351.1	19.9	1312.5	26.3	1263.8	33.5	1201.0	41.3	-	-
	2500	1751.6	27.3	1715.6	34.4	1670.3	42.6	1612.2	51.8	-	-
	3000	2158.9	35.2	2125.4	43.1	2083.5	52.3	2030.1	62.9	-	-
	3600	2656.4	45.5	2626.0	54.3	2588.2	64.8	2540.3	77.0	-	-
160CDL480 RC2	1000	551.4	10.3	529.4	12.8	502.3	15.8	468.7	19.4	427.1	23.5
	1500	934.9	19.4	912.6	22.1	885.2	25.3	851.1	29.3	808.7	33.8
	2000	1321.9	29.0	1299.3	31.9	1271.5	35.4	1236.9	39.7	1193.8	44.8
	2500	1712.3	39.3	1689.4	42.4	1661.3	46.1	1626.2	50.8	1582.3	56.4
	3000	2106.1	50.2	2083.0	53.5	2054.5	57.5	2018.9	62.4	1974.2	68.5
	3600	2583.3	64.0	2559.8	67.5	2530.9	71.8	2494.6	77.2	2449.1	83.9
160CDL480 RC3	1000	-	-	-	-	431.7	19.8	412.8	20.8	385.1	22.5
	1500	-	-	-	-	815.7	32.9	798.7	33.6	773.7	34.8
	2000	-	-	-	-	1201.6	46.7	1186.4	47.0	1164.2	47.7
	2500	-	-	-	-	1589.3	61.0	1576.0	61.1	1556.6	61.3
	3000	-	-	-	-	1979.0	76.0	1967.6	75.7	1950.9	75.4
	3600	-	-	-	-	2449.0	94.8	2439.9	94.1	2426.5	93.3

DIMENSIONS IN INCHES UNLESS OTHERWISE NOTED

MODEL	A	B	C	D	E	F	G	H	J	K	L	M
160CDL480	10.25	5.51	42.63	9.5	9.5	7.7	21.3	19.75	2.76	12 × 20 × 125 (mm)	26.28	9
	N	P	Q	R	S	T	U	V	W	X	Y	
	10" ANSI125FF	34.38	7.46	26.5	18	9	5.94	10.9	8" ANSI125FF	0.69	.69 × .94	

HIGH PRESSURE - PERFORMANCE DATA

MODEL	SPEED RPM	21 PSIG		24 PSIG		27 PSIG		30 PSIG		33 PSIG		36 PSIG	
		CFM	BHP	CFM	BHP	CFM	BHP	CFM	BHP	CFM	BHP	CFM	BHP
160CDL480 RC1	1000	-	-	-	-	-	-	-	-	-	-	-	-
	1500	-	-	-	-	-	-	-	-	-	-	-	-
	2000	-	-	-	-	-	-	-	-	-	-	-	-
	2500	-	-	-	-	-	-	-	-	-	-	-	-
	3000	-	-	-	-	-	-	-	-	-	-	-	-
	3600	-	-	-	-	-	-	-	-	-	-	-	-
160CDL480 RC2	1000	351.6	56.0	319.5	64.8	-	-	-	-	-	-	-	-
	1500	737.4	82.7	705.6	94.4	673.0	106.6	-	-	-	-	-	-
	2000	1130.1	110.4	1098.6	125.0	1066.4	140.1	1033.3	155.8	-	-	-	-
	2500	1529.8	139.2	1498.6	156.7	1466.6	174.7	1433.8	193.2	-	-	-	-
	3000	1936.3	168.9	1905.5	189.3	1873.8	210.2	1841.3	231.7	-	-	-	-
	3600	2433.4	206.0	2402.8	229.9	2371.5	254.3	2339.4	279.2	-	-	-	-
160CDL480 RC3	1000	366.8	56.2	352.8	62.1	336.5	68.6	-	-	-	-	-	-
	1500	743.0	84.1	729.3	92.0	713.4	100.4	695.2	109.5	674.6	119.1	-	-
	2000	1130.6	113.6	1117.3	123.4	1101.7	133.9	1083.8	144.9	1063.6	156.4	1041.2	168.6
	2500	1529.6	144.6	1516.7	156.4	1501.5	168.9	1483.9	181.8	1464.1	195.4	1442.0	209.5
	3000	1940.1	177.2	1927.5	191.0	1912.7	205.4	1895.5	220.4	1876.0	235.9	1854.3	252.0
	3600	2447.8	218.4	2435.6	234.6	2421.2	251.4	2404.5	268.8	2385.4	286.7	2364.1	305.1

HIGH VACUUM - PERFORMANCE DATA

MODEL	SPEED RPM	18 IN HG		19 IN HG		20 IN HG		21 IN HG		22 IN HG	
		CFM	BHP	CFM	BHP	CFM	BHP	CFM	BHP	CFM	BHP
160CDL480 RC1	1000	-	-	-	-	-	-	-	-	-	-
	1500	-	-	-	-	-	-	-	-	-	-
	2000	-	-	-	-	-	-	-	-	-	-
	2500	-	-	-	-	-	-	-	-	-	-
	3000	-	-	-	-	-	-	-	-	-	-
	3600	-	-	-	-	-	-	-	-	-	-
160CDL480 RC2	1000	411.4	24.9	395.2	26.1	378.9	27.2	-	-	-	-
	1500	792.7	35.4	776.1	37.0	759.4	38.3	-	-	-	-
	2000	1177.4	46.6	1160.4	48.4	1143.2	50.1	-	-	-	-
	2500	1565.6	58.4	1548.2	60.5	1530.5	62.5	-	-	-	-
	3000	1957.2	70.8	1939.4	73.1	1921.3	75.4	-	-	-	-
	3600	2431.7	86.5	2413.4	89.1	2394.7	91.8	-	-	-	-
160CDL480 RC3	1000	372.8	23.3	358.3	24.3	340.9	25.6	319.5	27.2	-	-
	1500	762.7	35.4	749.6	36.1	733.9	37.1	714.7	38.4	690.7	40.2
	2000	1154.4	48.1	1142.7	48.6	1128.8	49.3	1111.7	50.2	1090.4	51.5
	2500	1548.0	61.4	1537.8	61.7	1525.6	62.0	1510.6	62.6	1492.0	63.4
	3000	1943.5	75.4	1934.7	75.4	1924.2	75.4	1911.4	75.6	1895.4	75.9
	3600	2420.5	92.9	2413.5	92.6	2405.1	92.3	2394.9	92.0	2382.1	91.8

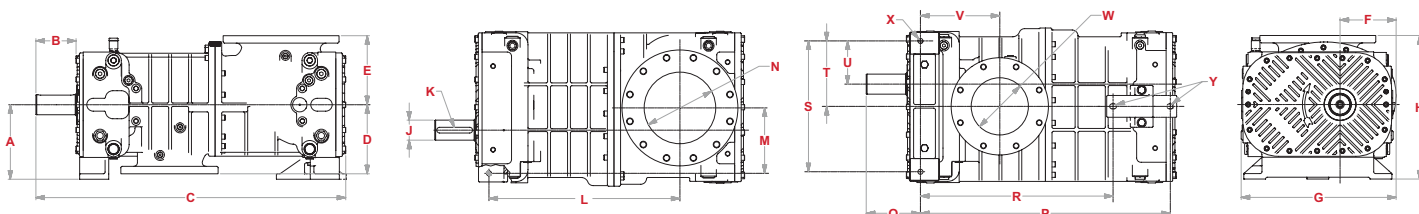

CycloBlower H.E. Performance Data

LOW PRESSURE - PERFORMANCE DATA

MODEL	SPEED RPM	5 PSIG		9 PSIG		12 PSIG		15 PSIG		18 PSIG		20 PSIG	
		CFM	BHP	CFM	BHP	CFM	BHP	CFM	BHP	CFM	BHP	CFM	BHP
200CDL600 RC1	800	891.7	23.4	806.7	39.7	749.6	52.7	698.1	66.2	-	-	-	-
	1200	1498.0	37.5	1416.0	61.7	1361.1	80.6	1311.9	100.0	1268.3	120.0	-	-
	1600	2102.4	52.6	2023.4	84.7	1970.8	109.4	1923.8	134.8	1882.5	160.7	-	-
	2000	2705.0	68.7	2629.0	108.6	2578.6	139.2	2533.9	170.5	2494.8	202.3	-	-
	2400	3305.8	85.7	3232.8	133.5	3184.6	170.0	3142.1	207.2	3105.3	245.0	-	-
	2800	3904.8	103.6	3834.7	159.3	3788.8	201.8	3748.5	244.9	3713.9	288.6	-	-
200CDL600 RC2	800	828.8	26.8	767.8	40.0	720.9	50.8	673.0	62.5	624.1	75.0	590.9	83.8
	1200	1459.7	44.6	1402.3	63.5	1358.0	78.6	1312.7	94.5	1266.5	111.2	1235.1	122.8
	1600	2078.8	64.1	2024.9	88.6	1983.2	107.9	1940.6	128.1	1897.0	149.0	1867.4	163.5
	2000	2686.0	85.3	2635.6	115.4	2596.6	138.9	2556.7	163.3	2515.7	188.5	2487.8	205.7
	2400	3281.4	108.0	3234.5	143.8	3198.2	171.6	3160.9	200.2	3122.6	229.6	3096.5	249.6
	2800	3864.9	132.4	3821.6	173.8	3787.9	205.8	3753.3	238.6	3717.6	272.3	3693.3	295.2
200CDL600 RC3	800	-	-	-	-	752.2	56.3	720.8	65.3	690.2	74.9	670.2	81.6
	1200	-	-	-	-	1360.3	91.7	1330.2	103.6	1300.9	116.0	1281.7	124.6
	1600	-	-	-	-	1969.1	129.5	1940.3	144.2	1912.3	159.5	1894.0	170.0
	2000	-	-	-	-	2578.6	169.7	2551.1	187.2	2524.5	205.3	2507.1	217.8
	2400	-	-	-	-	3188.9	212.2	3162.8	232.6	3137.4	253.6	3120.9	267.9
	2800	-	-	-	-	3800.0	257.1	3775.2	280.4	3751.1	304.2	3735.5	320.4

LOW VACUUM - PERFORMANCE DATA

MODEL	SPEED RPM	5 IN HG		8 IN HG		11 IN HG		14 IN HG		17 IN HG	
		CFM	BHP	CFM	BHP	CFM	BHP	CFM	BHP	CFM	BHP
200CDL600 RC1	800	924.8	11.3	884.1	18.2	833.3	25.7	768.5	32.9	-	-
	1200	1509.0	21.1	1468.9	29.2	1418.9	38.3	1355.3	47.8	-	-
	1600	2104.4	31.4	2064.9	40.8	2015.7	51.5	1953.2	63.3	-	-
	2000	2711.0	42.4	2672.1	53.0	2623.6	65.4	2562.2	79.4	-	-
	2400	3328.8	54.0	3290.4	65.9	3242.8	79.8	3182.5	96.1	-	-
	2800	3957.7	66.2	3919.9	79.3	3873.1	94.9	3813.9	113.4	-	-
200CDL600 RC2	800	886.4	15.9	853.4	19.5	812.7	23.9	761.9	29.1	698.5	35.0
	1200	1479.6	29.0	1446.4	33.0	1405.6	37.8	1354.5	43.6	1290.8	50.5
	1600	2077.2	43.3	2043.9	47.7	2002.8	53.0	1951.5	59.5	1887.4	67.3
	2000	2679.1	59.0	2645.7	63.8	2604.4	69.6	2552.9	76.7	2488.4	85.4
	2400	3285.4	76.1	3251.8	81.2	3210.4	87.4	3158.6	95.2	3093.7	104.9
	2800	3896.0	94.4	3862.3	99.9	3820.7	106.6	3768.6	115.0	3703.4	125.6
200CDL600 RC3	800	-	-	-	-	833.6	29.8	796.7	30.1	748.0	31.0
	1200	-	-	-	-	1421.9	49.9	1384.1	49.6	1334.1	49.8
	1600	-	-	-	-	2014.8	71.3	1976.1	70.5	1924.7	69.9
	2000	-	-	-	-	2612.1	94.1	2572.5	92.8	2519.8	91.3
	2400	-	-	-	-	3214.0	118.2	3173.5	116.3	3119.5	114.1
	2800	-	-	-	-	3820.4	143.7	3779.1	141.3	3723.7	138.3

DIMENSIONS IN INCHES UNLESS OTHERWISE NOTED

MODEL	A	B	C	D	E	F	G	H	J	K	L	M
200CDL600	12.00	7.05	51.59	11.00	11.00	9.52	26.21	23.00	3.54 (90mm)	14 × 25 × 140 (mm)	33.04	11.75
	N	P	Q	R	S	T	U	V	W	X	Y	
	12" ANSI125FF	42.16	8.39	34.29	23.50	11.75	7.75	13.23	10" ANSI125FF	0.81	.69 × .94	

HIGH PRESSURE - PERFORMANCE DATA

MODEL	SPEED RPM	21 PSIG		24 PSIG		27 PSIG		30 PSIG		33 PSIG		36 PSIG	
		CFM	BHP	CFM	BHP	CFM	BHP	CFM	BHP	CFM	BHP	CFM	BHP
200CDL600 RC1	800	-	-	-	-	-	-	-	-	-	-	-	-
	1200	-	-	-	-	-	-	-	-	-	-	-	-
	1600	-	-	-	-	-	-	-	-	-	-	-	-
	2000	-	-	-	-	-	-	-	-	-	-	-	-
	2400	-	-	-	-	-	-	-	-	-	-	-	-
	2800	-	-	-	-	-	-	-	-	-	-	-	-
200CDL600 RC2	800	574.2	88.3	523.3	102.5	-	-	-	-	-	-	-	-
	1200	1219.2	128.8	1170.9	147.1	1121.7	166.3	-	-	-	-	-	-
	1600	1852.4	170.8	1806.8	193.4	1760.1	216.9	1712.5	241.1	-	-	-	-
	2000	2473.7	214.5	2430.8	241.3	2386.8	269.0	2341.8	297.5	-	-	-	-
	2400	3083.2	259.8	3042.9	290.9	3001.6	322.8	2959.3	355.5	-	-	-	-
	2800	3680.9	306.8	3643.3	342.1	3604.6	378.2	3564.9	415.1	-	-	-	-
200CDL600 RC3	800	660.3	85.0	631.3	95.7	603.0	107.1	575.5	119.0	-	-	-	-
	1200	1272.3	129.0	1244.6	142.6	1217.6	156.7	1191.5	171.5	1166.1	186.8	1141.5	202.8
	1600	1885.1	175.3	1858.6	191.8	1833.0	208.8	1808.2	226.4	1784.1	244.6	1760.9	263.4
	2000	2498.6	224.1	2473.5	243.4	2449.2	263.2	2425.6	283.7	2402.9	304.8	2381.0	326.4
	2400	3112.8	275.2	3089.0	297.3	3066.1	320.0	3043.8	343.4	3022.4	367.3	3001.8	391.8
	2800	3727.9	328.6	3705.4	353.6	3683.7	379.2	3662.8	405.4	3642.7	432.2	3623.4	459.5

HIGH VACUUM - PERFORMANCE DATA

MODEL	SPEED RPM	18 IN HG		19 IN HG		20 IN HG		21 IN HG		22 IN HG	
		CFM	BHP	CFM	BHP	CFM	BHP	CFM	BHP	CFM	BHP
200CDL600 RC1	800	-	-	-	-	-	-	-	-	-	-
	1200	-	-	-	-	-	-	-	-	-	-
	1600	-	-	-	-	-	-	-	-	-	-
	2000	-	-	-	-	-	-	-	-	-	-
	2400	-	-	-	-	-	-	-	-	-	-
	2800	-	-	-	-	-	-	-	-	-	-
200CDL600 RC2	800	674.4	36.9	649.3	38.7	623.9	40.1	-	-	-	-
	1200	1266.5	52.8	1241.2	55.1	1215.5	57.1	-	-	-	-
	1600	1863.0	70.1	1837.5	72.8	1811.6	75.4	-	-	-	-
	2000	2463.8	88.6	2438.1	91.9	2411.9	95.1	-	-	-	-
	2400	3069.0	108.5	3043.1	112.3	3016.7	116.1	-	-	-	-
	2800	3678.5	129.7	3652.4	134.0	3625.8	138.4	-	-	-	-
200CDL600 RC3	800	728.3	31.6	706.6	32.5	682.8	33.8	657.1	35.7	630.1	38.7
	1200	1313.8	50.1	1291.4	50.5	1266.8	51.3	1240.0	52.6	1211.8	54.8
	1600	1903.8	69.8	1880.7	69.9	1855.3	70.2	1827.5	70.9	1798.0	72.3
	2000	2498.4	90.9	2474.6	90.6	2448.3	90.4	2419.5	90.4	2388.8	91.1
	2400	3097.5	113.4	3073.0	112.6	3045.9	111.9	3016.1	111.4	2984.0	111.2
	2800	3701.1	137.2	3675.9	136.0	3648.0	134.8	3617.1	133.7	3583.8	132.8

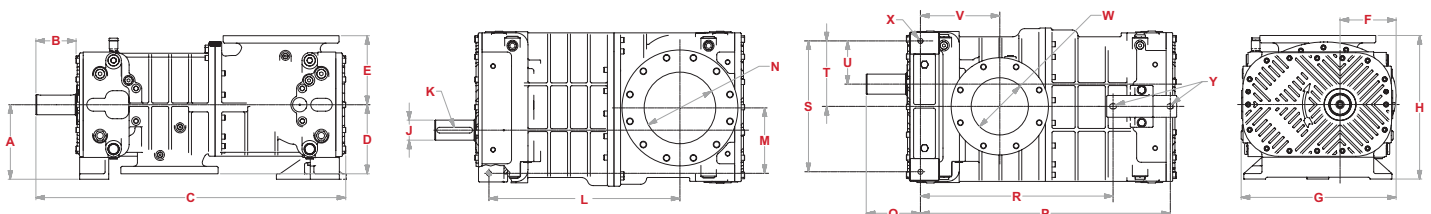

CycloBlower H.E. Performance Data

LOW PRESSURE - PERFORMANCE DATA

MODEL	SPEED RPM	5 PSIG		9 PSIG		12 PSIG		15 PSIG		18 PSIG		20 PSIG	
		CFM	BHP	CFM	BHP	CFM	BHP	CFM	BHP	CFM	BHP	CFM	BHP
250CDL750 RC1	500	893.1	28.5	756.4	50.1	670.2	67.3	598.2	85.4	-	-	-	-
	840	1889.2	50.0	1754.3	84.6	1669.5	111.4	1598.8	139.2	-	-	-	-
	1180	2903.1	74.4	2769.9	121.9	2686.5	158.5	2617.2	195.9	2561.9	234.2	-	-
	1520	3934.6	101.7	3803.3	162.1	3721.2	208.4	3653.2	255.5	3599.3	303.5	-	-
	1860	4983.9	131.9	4854.4	205.2	4773.7	261.1	4707.0	318.0	4654.4	375.7	-	-
	2200	6050.9	164.9	5923.2	251.1	5843.8	316.8	5778.5	383.3	5727.3	450.7	-	-
250CDL750 RC2	500	872.9	32.4	785.8	49.9	721.9	63.9	659.3	78.5	-	-	-	-
	840	1902.3	60.7	1819.2	88.5	1758.3	110.0	1698.6	132.3	1640.2	155.2	1602.0	170.9
	1180	2938.7	92.6	2859.5	130.5	2801.6	159.7	2744.9	189.6	2689.5	220.2	2653.2	241.0
	1520	3982.1	127.9	3906.9	176.1	3851.9	212.9	3798.2	250.5	3745.7	288.8	3711.4	314.6
	1860	5032.4	166.8	4961.1	225.2	4909.1	269.7	4858.4	314.9	4808.9	360.8	4776.6	391.8
	2200	6089.7	209.2	6022.4	277.8	5973.4	329.9	5925.6	382.8	5879.0	436.4	5848.7	472.4
250CDL750 RC3	500	-	-	-	-	692.0	64.9	644.6	77.3	-	-	-	-
	840	-	-	-	-	1679.6	120.5	1634.0	137.3	1589.4	155.3	1560.1	167.8
	1180	-	-	-	-	2693.6	183.2	2649.8	204.6	2606.9	227.1	2578.9	242.7
	1520	-	-	-	-	3734.0	253.1	3691.9	279.1	3650.9	306.2	3624.0	324.8
	1860	-	-	-	-	4800.7	330.2	4760.5	360.8	4721.2	392.4	4695.5	414.1
	2200	-	-	-	-	5893.9	414.5	5855.4	449.6	5817.9	485.8	5793.5	510.5

LOW VACUUM - PERFORMANCE DATA

MODEL	SPEED RPM	5 IN HG		8 IN HG		11 IN HG		14 IN HG		17 IN HG	
		CFM	BHP	CFM	BHP	CFM	BHP	CFM	BHP	CFM	BHP
250CDL750 RC1	500	1035.2	13.5	944.1	23.1	838.5	32.8	719.7	40.9	-	-
	840	2076.5	27.6	1987.9	39.7	1885.5	52.8	1771.1	65.3	-	-
	1180	3106.6	43.3	3020.4	58.0	2921.2	74.3	2811.3	91.4	-	-
	1520	4125.4	60.8	4041.7	77.9	3945.8	97.6	3840.3	119.2	-	-
	1860	5133.1	79.8	5051.8	99.5	4959.1	122.4	4858.1	148.6	-	-
	2200	6129.5	100.6	6050.6	122.7	5961.1	149.0	5864.6	179.7	-	-
250CDL750 RC2	500	978.3	16.2	927.9	22.1	865.2	29.0	785.3	36.9	682.3	45.3
	840	2005.1	38.3	1958.2	44.9	1900.1	52.6	1826.8	61.7	1733.1	71.8
	1180	3037.3	63.0	2994.0	70.2	2940.6	78.7	2873.6	89.0	2789.4	100.7
	1520	4075.0	90.3	4035.3	98.0	3986.5	107.4	3925.9	118.8	3851.1	132.2
	1860	5118.1	120.0	5081.9	128.4	5037.8	138.7	4983.7	151.2	4918.3	166.3
	2200	6166.7	152.4	6134.1	161.4	6094.6	172.5	6046.9	186.1	5990.9	202.9
250CDL750 RC3	500	-	-	-	-	832.1	32.5	773.3	34.8	689.3	39.6
	840	-	-	-	-	1849.7	65.2	1796.4	65.9	1720.6	68.3
	1180	-	-	-	-	2868.2	102.0	2820.5	101.1	2752.7	101.0
	1520	-	-	-	-	3887.6	142.8	3845.4	140.2	3785.8	137.8
	1860	-	-	-	-	4907.9	187.5	4871.3	183.3	4819.8	178.5
	2200	-	-	-	-	5929.0	236.3	5898.0	230.5	5854.6	223.3

DIMENSIONS IN INCHES UNLESS OTHERWISE NOTED

MODEL	A	B	C	D	E	F	G	H	J	K	L	M
250CDL750	15.88	8.42	63.65	13.00	13.00	10.55	31.18	28.88	3.94 (100mm)	16 x 28 x 180 (mm)	38.47	13.75
	N	P	Q	R	S	T	U	V	W	X	Y	
	14" ANSI125FF	48.00	10.94	N/A	27.50	13.75	8.50	18.00	12" ANSI125FF	0.88	.88 x 1.75	

HIGH PRESSURE - PERFORMANCE DATA

MODEL	SPEED RPM	21 PSIG		24 PSIG		27 PSIG		30 PSIG		33 PSIG		36 PSIG	
		CFM	BHP	CFM	BHP	CFM	BHP	CFM	BHP	CFM	BHP	CFM	BHP
250CDL750 RC1	500	-	-	-	-	-	-	-	-	-	-	-	-
	840	-	-	-	-	-	-	-	-	-	-	-	-
	1180	-	-	-	-	-	-	-	-	-	-	-	-
	1520	-	-	-	-	-	-	-	-	-	-	-	-
	1860	-	-	-	-	-	-	-	-	-	-	-	-
	2200	-	-	-	-	-	-	-	-	-	-	-	-
250CDL750 RC2	500	537.9	109.7	-	-	-	-	-	-	-	-	-	-
	840	1583.1	178.9	1527.2	203.2	1472.5	228.1	-	-	-	-	-	-
	1180	2635.3	251.5	2582.4	283.5	2530.7	316.1	2480.2	349.4	-	-	-	-
	1520	3694.5	327.7	3644.5	367.3	3595.8	407.6	3548.3	448.5	-	-	-	-
	1860	4760.6	407.4	4713.6	454.6	4667.8	502.6	4623.3	551.2	-	-	-	-
	2200	5833.7	490.6	5789.7	545.5	5746.8	601.1	5705.3	657.4	-	-	-	-
250CDL750 RC3	500	552.8	105.1	-	-	-	-	-	-	-	-	-	-
	840	1545.7	174.3	1503.0	194.4	1461.3	215.5	-	-	-	-	-	-
	1180	2565.0	250.7	2524.1	275.3	2484.2	301.0	2445.2	327.8	2407.2	355.7	-	-
	1520	3610.8	334.3	3571.6	363.5	3533.5	393.7	3496.3	425.1	3460.0	457.5	3424.8	491.0
	1860	4682.9	425.1	4645.5	458.8	4609.1	493.7	4573.7	529.5	4539.3	566.5	4505.8	604.5
	2200	5781.4	523.1	5745.8	561.4	5711.2	600.8	5677.6	641.2	5644.9	682.7	5613.2	725.3

HIGH VACUUM - PERFORMANCE DATA

MODEL	SPEED RPM	18 IN HG		19 IN HG		20 IN HG		21 IN HG		22 IN HG	
		CFM	BHP	CFM	BHP	CFM	BHP	CFM	BHP	CFM	BHP
250CDL750 RC1	500	-	-	-	-	-	-	-	-	-	-
	840	-	-	-	-	-	-	-	-	-	-
	1180	-	-	-	-	-	-	-	-	-	-
	1520	-	-	-	-	-	-	-	-	-	-
	1860	-	-	-	-	-	-	-	-	-	-
	2200	-	-	-	-	-	-	-	-	-	-
250CDL750 RC2	500	641.7	47.8	597.9	49.7	-	-	-	-	-	-
	840	1696.7	75.0	1657.8	77.8	1617.1	79.8	-	-	-	-
	1180	2757.2	104.7	2723.2	108.4	2688.5	111.5	-	-	-	-
	1520	3823.1	137.0	3794.1	141.6	3765.3	145.7	-	-	-	-
	1860	4894.4	171.8	4870.4	177.3	4847.6	182.4	-	-	-	-
	2200	5971.3	209.1	5952.2	215.5	5935.3	221.7	-	-	-	-
250CDL750 RC3	500	652.7	42.2	610.0	45.7	559.7	50.5	-	-	-	-
	840	1687.6	69.9	1649.2	72.1	1604.0	75.4	1550.1	80.2	-	-
	1180	2723.4	101.5	2689.3	102.5	2649.2	104.2	2601.6	107.2	2544.0	112.3
	1520	3760.1	137.2	3730.3	136.9	3695.4	137.1	3654.0	138.3	3604.3	141.0
	1860	4797.7	176.9	4772.1	175.3	4742.4	174.0	4707.3	173.3	4665.5	173.7
	2200	5836.1	220.6	5814.9	217.7	5790.3	214.9	5761.5	212.4	5727.6	210.5

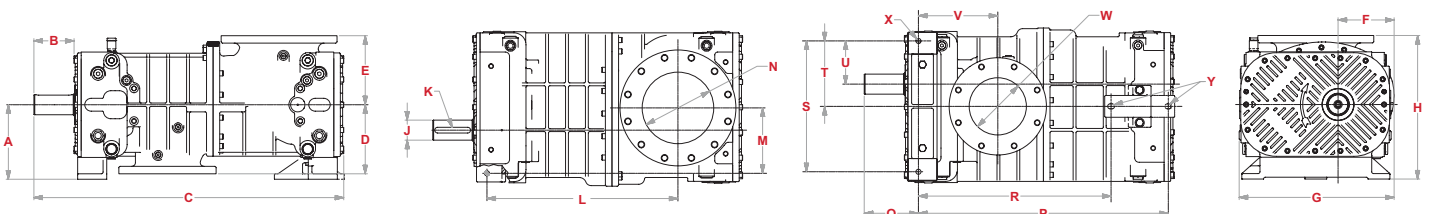

The leader in every market we serve
by continuously improving all business processes
with a focus on innovation and velocity

Gardner
Denver[®]

Gardner Denver, Inc.

1800 Gardner Expressway
Quincy, IL 62305
866-428-4890

www.gardnerdenver.com/gdproducts



©2017 Gardner Denver, Inc. Printed in U.S.A.
PD-CB-HE 3rd Ed. 9/17

 Please recycle after use.